

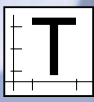

Self-adhesive cable tie mounts

Flexible and solid fixing solutions





Information and installation instructions for self-adhesive mounting bases

HellermannTyton uses different types of adhesives for self-adhesive bases: acrylate and synthetic rubber. These differ in the operating temperature range and the 'pull off' force of the adhesive. Synthetic rubber has an excellent initial grip, allowing for almost immediate use. Acrylate adhesive has less initial grip, so there is a need to wait for a few hours before use, but has a higher 'pull off' force than synthetic rubber. This enables a permanent fixing lasting months or even years.

ADHESIVE		Adhesive Operating Temperature
Acrylate with base of acrylic foam	mod. Acrylate	-30 °C to +120 °C

Instructions for use

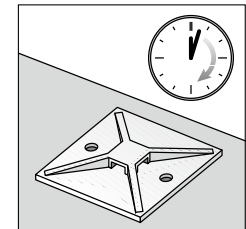
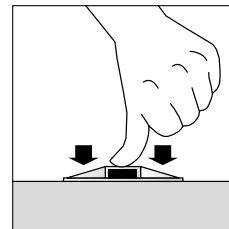
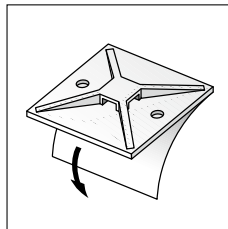
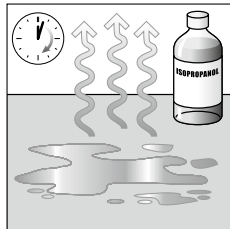

1. The surface must be dry, free from dust, oil, oxides, parting agents and other impurities. The surface to be glued should be cleaned using a clean cloth and isopropanol/water (50/50). When using other appropriate cleaning agents, ensure that they do not attack the surface nor leave any residues. After cleaning allow the surface to air-dry completely.

2. Peel off protective backing and ensure the adhesive area is not touched.

3. Press down firmly on the base with the thumbs for several seconds.

4. Depending on the type of adhesive, wait for several minutes (synthetic rubber) or hours (acrylate) so that the adhesive can bond completely with the surface.



We will be happy to send you on request an up-to-date technical datasheet for whichever adhesive you are using.

Advantages of our self-adhesive mounts with mod. Acrylate (SolidTack / FlexTack)

- Acrylic Foam Tape is made from a homogeneous system of high performance acrylic adhesive
- Very good initial bond
- High temperature resistance
- Adhesive offers design freedom, no need for bolts or screws
- Reduces the risk of corrosion, no need for boreholes
- Weight reduction compared to mechanical mounting
- Possibility to optimize production processes and to reduce production cost (bonding vs. screwing)
- Can compensate unevenness up to a certain degree
- Specially developed for low energy surfaces

Load types on adhesive bonds

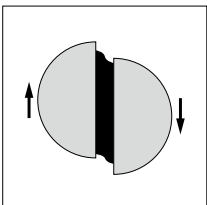

Shear resistance.

Shear force pulls the adhesive surfaces in opposite directions along a parallel line.

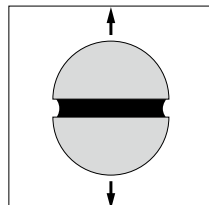

Tensile strength.

Tension force pulls surfaces apart perpendicular to the adhesive bond.

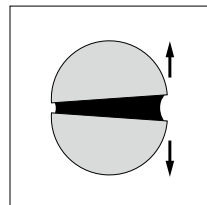

Cleavage resistance.

Cleavage can occur where forces acting on bonded surfaces are not evenly spread but concentrated along a single line.

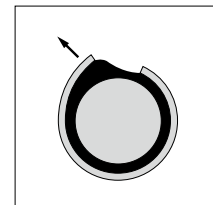

Peel adhesion.

Peeling force acts on a small amount of adhesive at the edge of the tape and weakens the adhesive bond. At least one adherend is flexible.

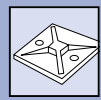

Cable Tie Mounts with high performance adhesive

SolidTack-Series MB

SolidTack MB Series mounts do have a square design and are fairly common in areas like electrical cabinet, railway, aerospace, automotive and agriculture machinery. The premium self-adhesive bonds well on high and low-energy surfaces like plastics, metal, varnish or paint and is suitable for a wide range of applications.

Features and Benefits

- MB mounts with homogeneous system of acrylic adhesive
- Very good initial adhesion, increases with time
- Adhesive with high cohesive strength combined with good weathering resistance
- Innovative fixing solution for high and low energy surfaces
- Protection foil with finger lift for easy peel off



SolidTack products work on varnished and powder coated surfaces.



One Step to the Web!

MATERIAL	Polyamide 6.6 (PA66)
Operating Temperature	-40 °C to +85 °C, (+105 °C, 500 h)
Flammability	UL94 V2 (excluding adhesive)
Adhesive	Acrylate with base of acrylic foam
Adhesive Operating Temperature	-30 °C to +120 °C

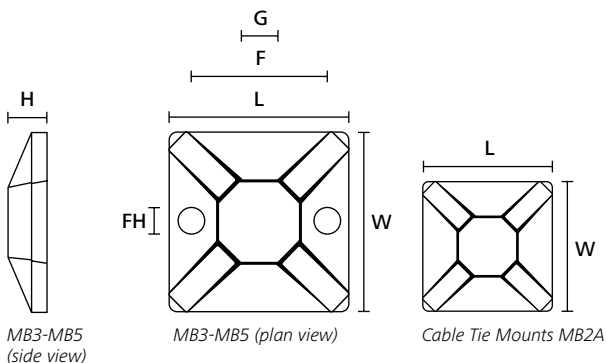

TYPE	Width (W)	Length (L)	Height (H)	Hole Ø (FH)	Fixing Hole Centres (F)	Strap Width max. (G)	Material	Colour	Adhesive	Pack Cont.	Article-No.
MB2APT-I	13.0	13.0	4.1	-	-	2.7	PA66	Black (BK)	mod. Acrylate	100 pcs.	151-01556
MB3APT-I	19.0	19.0	3.8	3.1	13.2	4.4	PA66	Black (BK)	mod. Acrylate	100 pcs.	151-01557
	19.0	19.0	3.8	3.1	13.2	4.4	PA66	White (WH)	mod. Acrylate	100 pcs.	151-01558
MB4APT-I	28.0	28.0	4.7	4.0	20.2	5.6	PA66	Black (BK)	mod. Acrylate	100 pcs.	151-01559
	28.0	28.0	4.7	4.0	20.2	5.6	PA66	White (WH)	mod. Acrylate	100 pcs.	151-01560
MB5APT-I	38.0	38.0	6.3	4.7	25.3	10.0	PA66	Black (BK)	mod. Acrylate	100 pcs.	151-01561

All dimensions in mm. Subject to technical changes.
Minimum Order Quantity (MOQ) may differ from package content. Other packaging options may also be available.

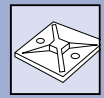

Cable Tie Mounts with high performance adhesive

SolidTack-Series FKH

These SolidTack FKH self-adhesive mounts can particularly be used in areas where it is not possible to route cables with conventional fixing solutions. The premium self-adhesive bonds well on high and low-energy surfaces like plastics, metal, varnish or paint and is suitable for a wide range of applications. Our FKH-Series has been specifically designed to guide flat ribbon cables, making it particularly suitable for cable installation in computer systems, gaming machines or domestic appliances.

Features and Benefits

- Mount especially developed to hold and guide flat ribbon cables
- FKH mounts with homogeneous system of acrylic adhesive
- Very good initial adhesion, increases with time
- Adhesive with high cohesive strength combined with good weathering resistance
- Innovative fixing solution for high and low energy surfaces
- Protection foil with finger lift for easy peel off



Based on extremely soft wings any flat cable is gently fastened.

MATERIAL	Polyamide 6.6, high impact modified (PA66HIR)
Operating Temperature	-40 °C to +80 °C, (+105 °C, 500 h)
Flammability	UL94 HB (excluding adhesive)
Adhesive	Acrylate with base of acrylic foam
Adhesive Operating Temperature	-30 °C to +120 °C



One Step to the Web!

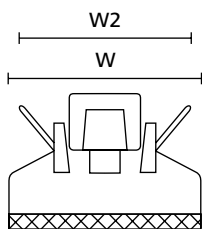

Flat Ribbon Cable Mount (front view)

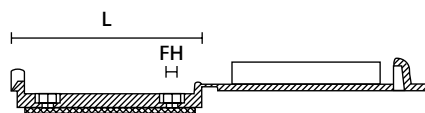

Flat Ribbon Cable Mount (side view)

TYPE	Width (W)	Width (W2)	Length (L)	Hole Ø (FH)	For Cable Width max.	Material	Colour	Adhesive	Pack Cont.	Article-No.
FKH50APT-I	25.0	22.0	56.5	3.1	50.0	PA66HIR	Black (BK)	mod. Acrylate	100 pcs.	151-01562
FKH80APT-I	25.0	22.0	86.0	3.1	80.0	PA66HIR	Black (BK)	mod. Acrylate	100 pcs.	151-01563

All dimensions in mm. Subject to technical changes.

Minimum Order Quantity (MOQ) may differ from package content. Other packaging options may also be available.

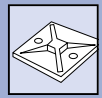

Cable Tie Mounts with high performance adhesive

SolidTack-Series QM

Q-mounts are ideally suited for holding our innovative Q-ties in place. They would perfectly fit to all applications where a reliable and durable fixation is required. With its SolidTack adhesive Q-mounts offer an innovative fixing solution especially for low energy surfaces or if drilling a hole is not possible. Suitable for a wide range of applications on varnished or plastic or metal surfaces in many areas like electrical cabinet, railway, aerospace, automotive and agriculture machinery.

Features and Benefits

- Q-mounts with homogeneous system of acrylic adhesive
- Perfect for combination with Q-ties
- Very good initial adhesion, increases with time
- Adhesive with high cohesive strength combined with good weathering resistance
- Innovative fixing solution for high and low energy surfaces
- Q-Mount base locks Q-tie in vertical position, means the hands are free to apply cables



Mounting bases Q-Mount.

MATERIAL	Polyamide 6.6 (PA66)
Operating Temperature	-40 °C to +85 °C, (+105 °C, 500 h)
Flammability	UL94 V2 (excluding adhesive)

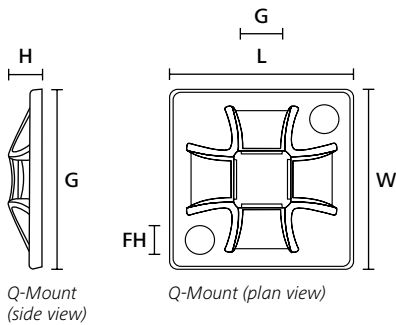

Q-Mount
(side view)

Q-Mount (plan view)

TYPE	Width (W)	Length (L)	Height (H)	Hole Ø (FH)	Strap Width max. (G)	Material	Colour	Adhesive	Pack Cont.	Article-No.
QM20APT-I	20.0	20.0	3.7	3.1	4.0	PA66	Black (BK)	mod. Acrylate	100 pcs.	151-01592
	20.0	20.0	3.7	3.1	4.0	PA66	Natural (NA)	mod. Acrylate	100 pcs.	151-01591
QM30APT-I	30.0	30.0	4.5	4.1	5.1	PA66	Black (BK)	mod. Acrylate	100 pcs.	151-01594
	30.0	30.0	4.5	4.1	5.1	PA66	Natural (NA)	mod. Acrylate	100 pcs.	151-01593
QM40APT-I	40.0	40.0	5.5	4.1	8.4	PA66	Black (BK)	mod. Acrylate	50 pcs.	151-01596
	40.0	40.0	5.5	4.1	8.4	PA66	Natural (NA)	mod. Acrylate	50 pcs.	151-01595

All dimensions in mm. Subject to technical changes.

Minimum Order Quantity (MOQ) may differ from package content. Other packaging options may also be available.



Cable Tie Mounts with high performance adhesive

FlexTack-Series FMB for round and angled surfaces

FlexTack cable tie mounts can be successfully applied to a variety of high- and low-energy surfaces such as glass, metals (including painted, varnished or powder-coated surfaces) as well as plastics. FlexTack provides a reliable fixing solution where it is impractical to use screws or bolts. The unique design in combination with the special acrylate adhesive makes professional cable management easy.

Features and Benefits

- Flexible Mount for round and angled surfaces
- FMB mounts with homogeneous system of acrylic adhesive
- Allows greater design freedom and offers uniform stress distribution along with weight reduction
- Adhesive with high cohesive strength combined with good weathering resistance
- Innovative fixing solution for high and low energy surfaces
- Protection foil with finger lift for easy peel off
- Temperature resistance up to +105 °C
- 4-way entry for cable tie for quicker and more flexible installation
- FMB4APT-I is also suitable for high energy surfaces like metal or glass



Flexible cable tie mount (FlexTack) in a concave application.

MATERIAL	Polyamide 6.6, heat stabilised (PA66HS)
Operating Temperature	-40 °C to +105 °C
Flammability	UL94 V2 (excluding adhesive)

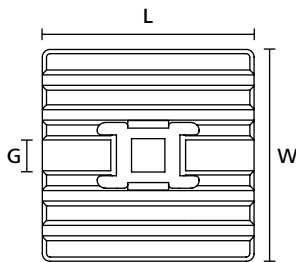

Flexible Adhesive Mount FMB4APT-I (plan view)

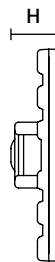

Flexible Adhesive Mount FMB4APT-I (side view)

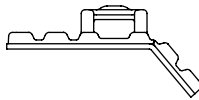

Flexible Adhesive Mount FMB4APT-I (down angled, side view)

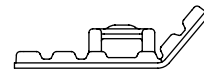

Flexible Adhesive Mount FMB4APT-I (up angled, side view)

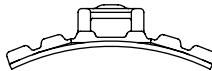

Flexible Adhesive Mount FMB4APT-I (convex, side view)

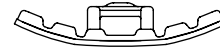

Flexible Adhesive Mount FMB4APT-I (concave, side view)

TYPE	Width (W)	Length (L)	Height (H)	Strap Width max. (G)	Material	Colour	Adhesive	Pack Cont.	Article-No.
FMB4APT-I	28.0	28.0	6.3	5.4	PA66HS	Black (BK)	mod. Acrylate	100 pcs.	151-01527
	28.0	28.0	6.3	5.4	PA66HS	White (WH)	mod. Acrylate	100 pcs.	151-01528

All dimensions in mm. Subject to technical changes.

Minimum Order Quantity (MOQ) may differ from package content. Other packaging options may also be available.